

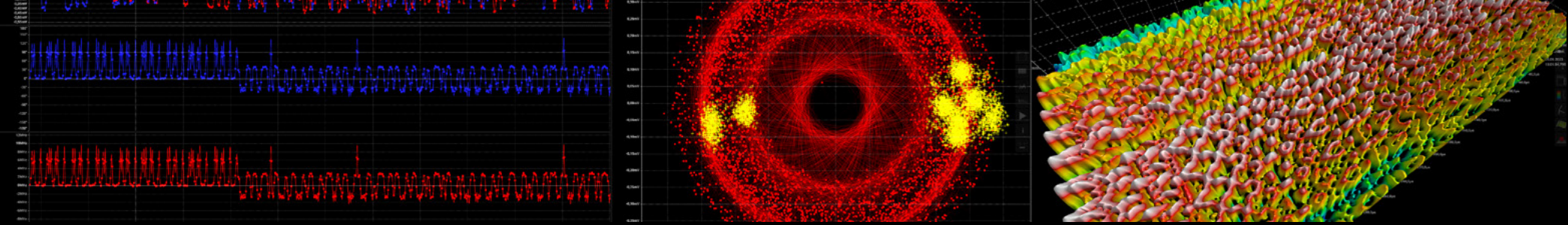

# SPECTRUM AWARENESS AND 3D GEOLOCATION

DIRECTION FINDING | DECODING | RECORDING | DEEP ANALYSIS



## Spectrum Management Introduction

Effective spectrum management is crucial in today's increasingly connected world, where reliable communication, data integrity, and electromagnetic compatibility are more critical than ever.

A comprehensive hardware and software approach to spectrum management addresses various challenges and delivers significant benefits, particularly when leveraging state-of-the-art real-time spectrum analysis solutions.

Thorough spectrum management is no longer optional; it's a necessity in a world driven by wireless communication and interconnected devices. State-of-the-art real-time spectrum hardware and software solutions not only address critical challenges but also empower organizations with the tools needed to ensure seamless, secure, and compliant operations in even the most complex environments.

With these technologies, businesses and governments can maintain control of the spectrum, turning potential obstacles into opportunities for growth and innovation.



## Spectrum Congestion and Interference

As wireless technologies proliferate, the frequency spectrum becomes crowded, leading to increased interference and vulnerability. This can degrade or disrupt the performance of critical systems, such as communication networks, IoT devices and even radar systems.



## Complex Signal Environments

Modern communication systems, such as 5G, Wi-Fi 6, and advanced radar, operate with highly complex modulation schemes that require sophisticated tools for effective analysis and troubleshooting.



## Regulatory Compliance

Ensuring adherence to international and regional spectrum regulations is a demanding task, especially in dynamic or high-traffic environments.

## Detection of Short-Lived Events

Intermittent or transient signals, such as burst transmissions or fleeting interference, are difficult to detect with traditional, non-real-time spectrum analyzers. This can lead to gaps in monitoring and unresolved issues.

## Security Threats

Unauthorized devices and eavesdropping attempts pose significant risks to data security, especially in defense, corporate, and critical infrastructure environments.

## Recording, Classification, and Decoding

Real-time spectrum data capture poses challenges in storage, processing, and decoding diverse signals like complex modulations or encrypted transmissions. Traditional systems often fall short, resulting in data gaps and reduced accuracy.

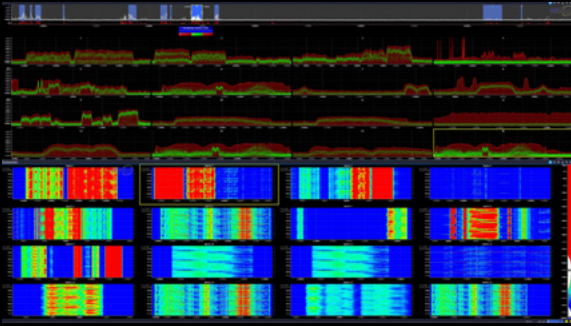

## Real-Time Data Capture and Processing

- Seamless event detection from 9kHz up to 140 GHz with a POI (signal duration) of under 2.5µs
- Scalable real-time bandwidths up to 4.9GHz with industry-leading sweep speeds of >3THz/s



## Classification and Decoding

- Real-time decoding of many signal events
- Decryption of LTE, Bluetooth, WiFi, ADS-B, QAM and many more
- Continuous development of decoding algorithms

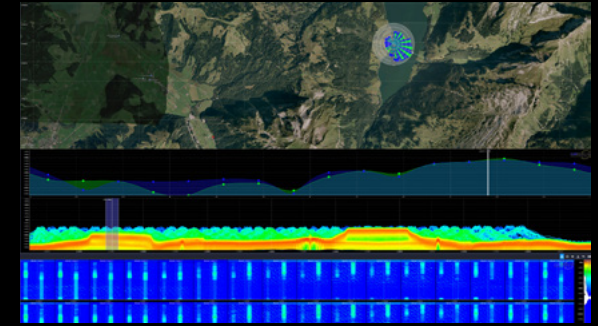

## Precise AoA and TDoA Direction Finding

- Advanced direction finding with an accuracy of 1° to 3° including elevation information
- POI (signal duration) of under 3µs
- Full network support with mesh-capability

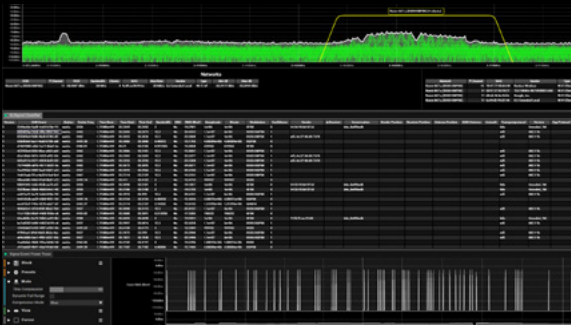

## Efficient Data Management

- Enhanced processing and data reduction
- Records the entire scanned frequency spectrum as full IQ data
- Intelligent database structure for fast evaluation



## Scalable and Customizable Solutions

- Flexible architecture and customizable hardware
- Covert integration into vans, transporters or offroad-trucks
- 24/7 stationary usage with full IP66 protection



## Robust Design for Field and Lab Applications

- TRL-9 and MRL-10 field-proven solutions
- Over 20 years of experience in the development and production of spectrum management solutions with hundreds of installations worldwide

# AARONIA MOBILE

SPECTRUM DOMINANCE ON THE GO

## The Precision MOBILE Direction Finding Solution.

The Aaronia **MOBILE** is a rugged, high-performance solution for manual sight survey and signal direction finding in demanding field environments. Combining the robust 15" Aaronia spectrum analyzer tablet with the powerful HyperLOG® directional antenna, this portable system delivers exceptional accuracy, real-time performance, and flexibility for RF professionals.

With an extended frequency range from 380MHz to 18GHz, the Aaronia **MOBILE** enables comprehensive detection, analysis, and tracking of radio signals across a vast spectrum. Its intuitive touchscreen interface and remote access options ensure seamless operation, whether used on the go or mounted in mobile applications.

Engineered for rapid deployment and long-term reliability, the system is ideal for tactical signal intelligence, interference hunting, and mobile spectrum monitoring. Its modular design allows for future upgrades, including integration with the Iso-LOG® antenna array—enabling automatic, highly accurate direction finding and 3D triangulation for advanced situational awareness.

Compact, durable, and mission-ready, the Aaronia **MOBILE** sets a new benchmark in RF intelligence technology on the go.



› Signal strength locator



› Rugged, compact and versatile for rapid deployments

### SPECTRAN® V6 TABLET

- › Ruggedized handheld real-time spectrum analyzer
- › 3THz/s sweep speed
- › High-end hardware with hot-swap batteries and extended runtime

### HyperLOG® LogPer Antenna

- › Handheld manual direction finding antenna
- › Broad frequency coverage from 380MHz to 18GHz
- › Exceptional gain with inbuilt amplifier

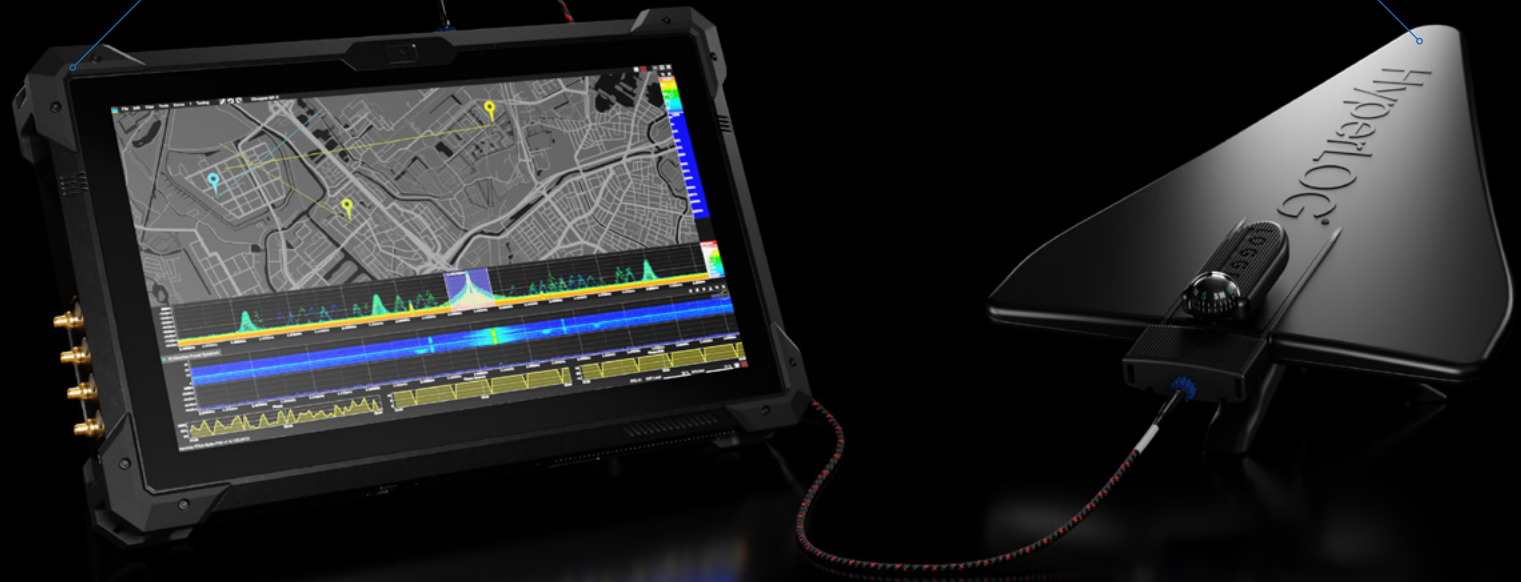

# The Precision Mobile Direction Finding Solution



## Type

Handheld LogPer

## Frequency Range

380MHz to 18GHz

## Signal Duration

> 250 $\mu$ s

## DF Accuracy

6 to 10°

## Sweep Speed

3THz/s

## RTBW

60MHz

# AARONIA MIL-COM

MISSION CRITICAL ACCURACY

## High-Frequency Intel. Field-Ready.

Aaronia MIL-COM is a mission-ready spectrum monitoring and signal intelligence platform engineered for high-mobility operations in challenging environments. Housed in a rugged, battery-powered MIL-spec laptop, it delivers uncompromising performance in real-time signal detection and geolocation across the X and Ku bands up to 18GHz.

Optimized for rapid threat identification, MIL-COM features 3THz/s sweep speed with 60MHz RTBW and an ultra-short POI  $>20\mu\text{s}$ , enabling the reliable capture of even the briefest and most agile transmissions. This makes it ideal for intercepting modern radar signals, low-duration bursts, and high-frequency SATCOM links.

The integrated 3D direction-finding antenna allows for accurate emitter geolocation, even in dynamic, remote, or contested environments. Designed for autonomy in the field, MIL-COM equips tactical teams with advanced spectrum awareness and signal analysis without dependence on fixed infrastructure.

Whether deployed for electronic warfare support, SATCOM monitoring, or border surveillance, Aaronia MIL-COM is the ultimate compact solution for achieving spectrum superiority in the field.

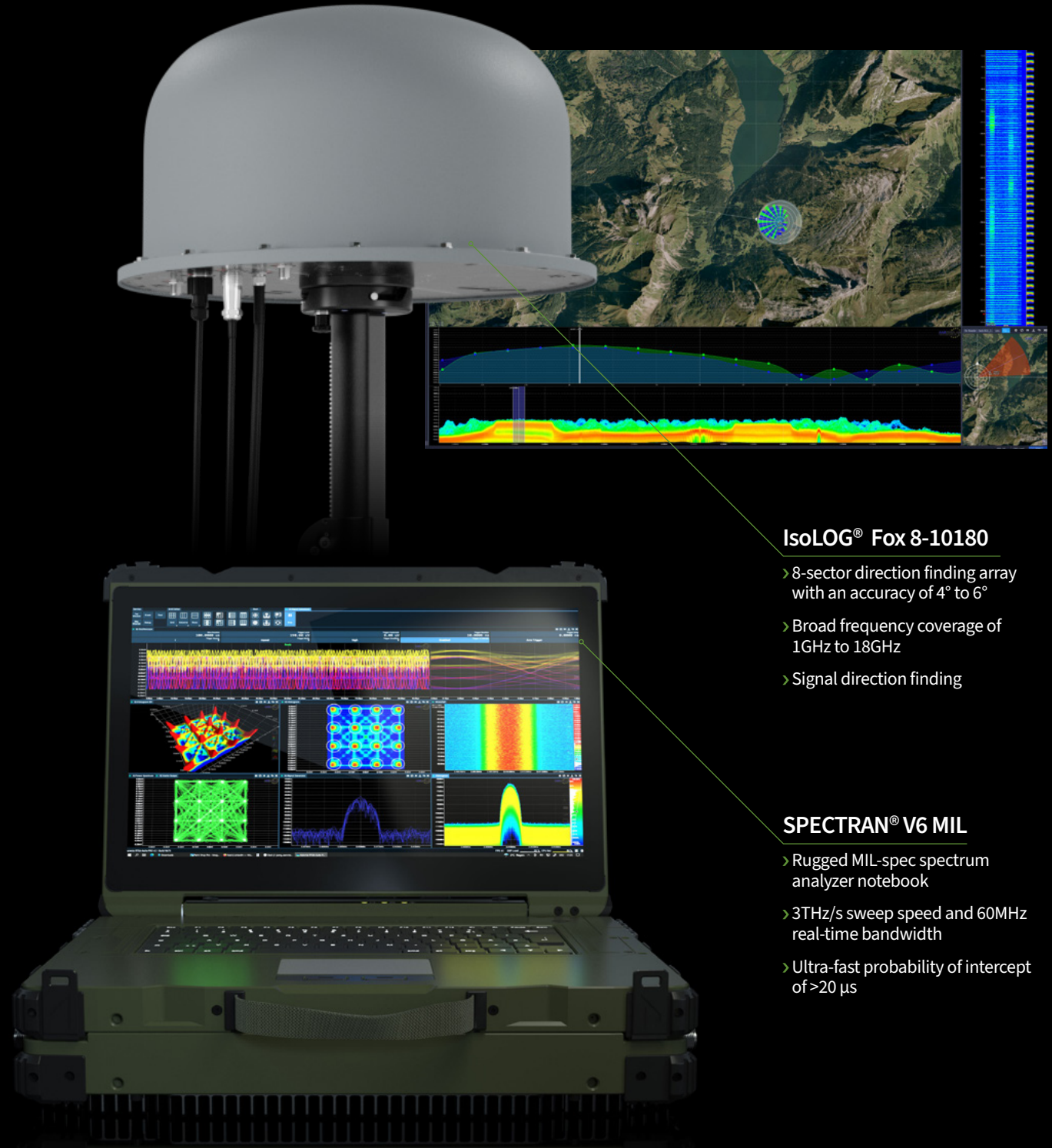

### IsoLOG® Fox 8-10180

- › 8-sector direction finding array with an accuracy of 4° to 6°
- › Broad frequency coverage of 1GHz to 18GHz
- › Signal direction finding

### SPECTRAN® V6 MIL

- › Rugged MIL-spec spectrum analyzer notebook
- › 3THz/s sweep speed and 60MHz real-time bandwidth
- › Ultra-fast probability of intercept of  $>20\mu\text{s}$

# High-Frequency Intel. Field-Ready.



**Type**  
Direction Finding Array

**Frequency Range**  
1GHz to 18GHz

**Signal Duration**  
>20 $\mu$ s

**DF Accuracy**  
4 to 6 $^{\circ}$

**Sweep Speed**  
3THz/s

**RTBW**  
60MHz

# AARONIA PORTABLE MESH

AGILITY MEETS PRECISION

## The Mobile Signal Intelligence Backpack.

The Aaronia **PORTABLE MESH** is the ultimate mobile solution for signal intelligence, offering unmatched performance in a rugged and compact design. Designed for professionals requiring precise and versatile tools, the **PORTABLE MESH** excels in direction finding, decoding, recording, and analysis.

Equipped with a broad frequency range from 150MHz to 8GHz and a high-end real-time spectrum analyzer capable of 490MHz bandwidth, the **PORTABLE MESH** ensures comprehensive signal coverage and analysis in real-time. Whether in the field or deployed for stationary use, this backpack is engineered to meet the toughest demands.

Control the **PORTABLE MESH** seamlessly via a laptop, tablet, or smartphone app, providing maximum flexibility and user convenience. For stationary operations, it features an extendable mast and ground anchors, enabling secure and effective deployment. Its mesh capability and remote access options allow integration into wider networks, making it an ideal tool for collaborative operations.

With a continuous runtime of up to 6 hours, the **PORTABLE MESH** is built for endurance, ensuring uninterrupted performance during critical missions. Compact, powerful, and versatile, the Aaronia **PORTABLE MESH** sets a new standard for mobile signal intelligence solutions.

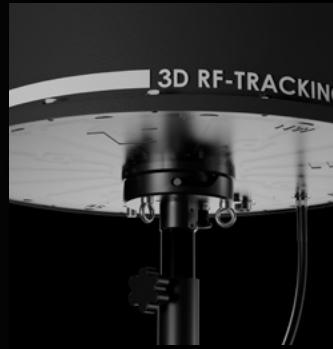

> Optimized materials for weight reduction



> Heavy-duty MIL-spec ergonomic backpack



> Ruggedized analyzer for 24/7/365 usage



### IsoLOG® FOX LT 16-10180

- > Lightweight 16-sector direction finding array
- > Broad frequency coverage from 1GHz up to 18GHz with 2° to 5° DF accuracy
- > Inbuilt UWB omni-antennas for decoding, recording and jamming

### Extendable Mast

- > Extension up to 2.5 meters
- > Anchor eyelets for a secure hold in the terrain

### SPECTRAN® V6 RODB

- > High-end ruggedized spectrum analyzer
- > Real-time bandwidth of up to 490MHz with 3THz/s sweep speed
- > 24/7 outdoor usage with mesh-capability and remote control
- > Mesh capability via LTE, Wi-Fi or Starlink

### MIL-Spec Backpack

- > Ergonomic design for easy handling
- > 17 - 31kg weight depending on powerpack
- > Available in 4 different colors (black, tan, sand, olive)

### PORTABLE MESH Powerpack

- > 3 sizes with a continuous deployment runtime of up to 6 hours
- > Weatherproof power inputs and outputs
- > Optimal weight distribution

# The Mobile Signal Intelligence Backpack



## Type

Direction Finding Array

## Frequency Range

150MHz up to 18GHz

## Signal Duration

> 50 $\mu$ s

## DF Accuracy

2 to 5 $^{\circ}$

## Sweep Speed

3THz/s

## RTBW

490MHz

# AARONIA COMMAND CENTER

THE ULTIMATE REAL-TIME BATTLESTATION

## Portable High-Performance Spectrum Analyzer.

The Aaronia **COMMAND CENTER** is a cutting-edge solution designed for advanced spectrum analysis tasks, offering exceptional performance in direction finding, decoding, recording, and analysis. When multiple units are used in a mesh, they enable highly precise 3D geolocation of any signal, making this device the ultimate choice for professionals handling complex signal environments.

Covering a broad frequency range from 400MHz to 8GHz, the **COMMAND CENTER** provides unparalleled versatility for diverse applications. Its high-end real-time spectrum analyzer features 980MHz bandwidth, ensuring precise and comprehensive analysis in real-time.

Equipped with massive high-speed IQ data recording space, it ensures seamless data capture for detailed post-event analysis. Its rugged design includes a 5 meter extendable mast, enabling optimal placement and enhanced signal detection, even in challenging environments.

Achieving TRL-9 (Technology Readiness Level) and MRL-10 (Manufacturing Readiness Level), the **COMMAND CENTER** exemplifies reliability and readiness for deployment in mission-critical operations. Compact, powerful, and designed to withstand demanding conditions, the Aaronia **COMMAND CENTER** redefines portable real-time spectrum analysis and situational awareness.



› Never miss a signal of interest with nearly 2 GHz real-time bandwidth



### SPECTRAN® V6 CC

- › Simultaneous 3THz/s sweep and 980MHz RTBW with real-time direction finding
- › Two 4K high-contrast displays
- › Powerful hardware with huge high-speed IQ data space

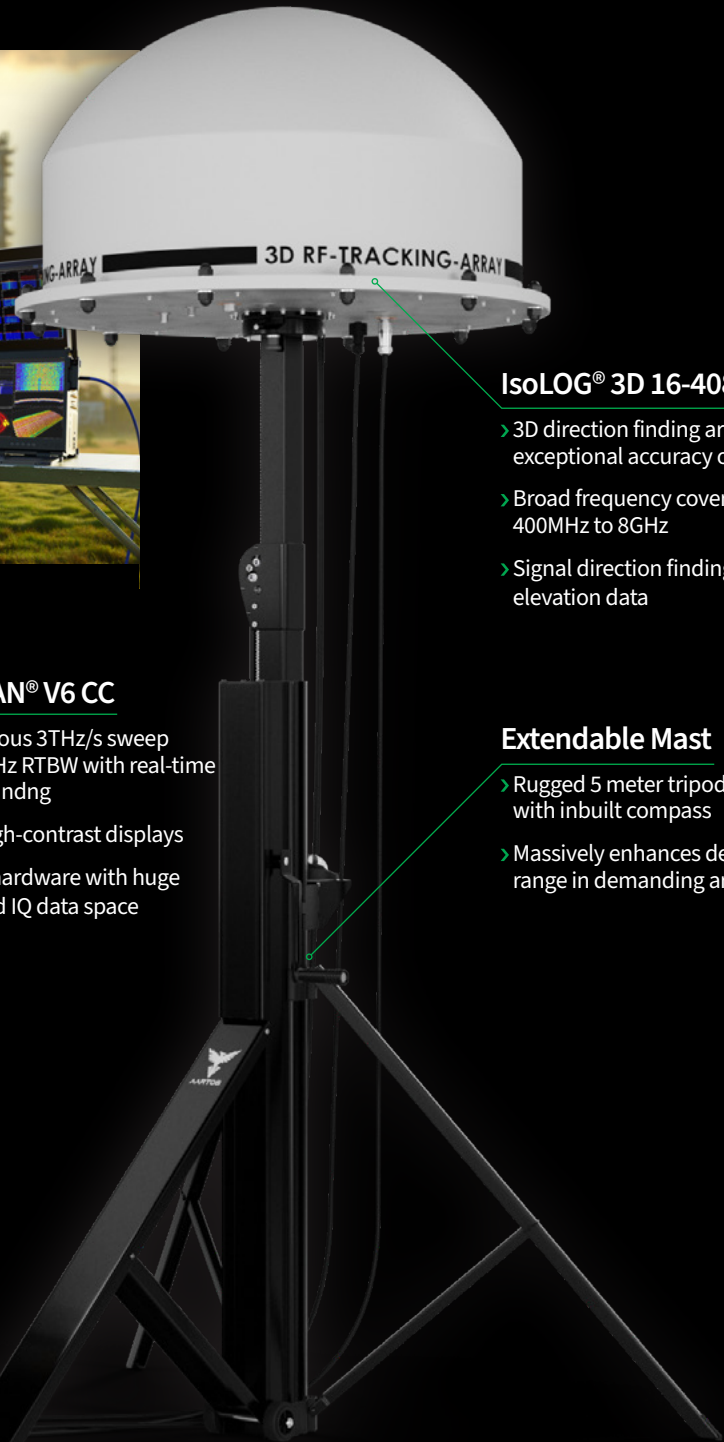

### IsoLOG® 3D 16-4080

- › 3D direction finding array with an exceptional accuracy of 1° to 3°
- › Broad frequency coverage of 400MHz to 8GHz
- › Signal direction finding including elevation data

### Extendable Mast

- › Rugged 5 meter tripod mast with inbuilt compass
- › Massively enhances detection range in demanding areas

# Portable High-Performance Spectrum Analyzer

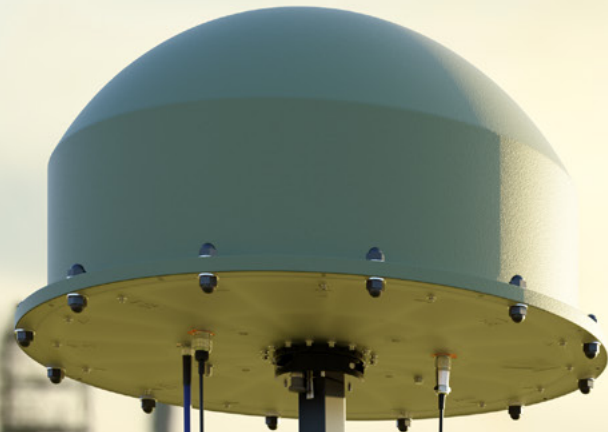

## Type

3D Direction Finding Array

## Frequency Range

400MHz to 8GHz

## Signal Duration

>3 $\mu$ s

## DF Accuracy

1 to 3°

## Sweep Speed

3THz/s

## RTBW

980MHz

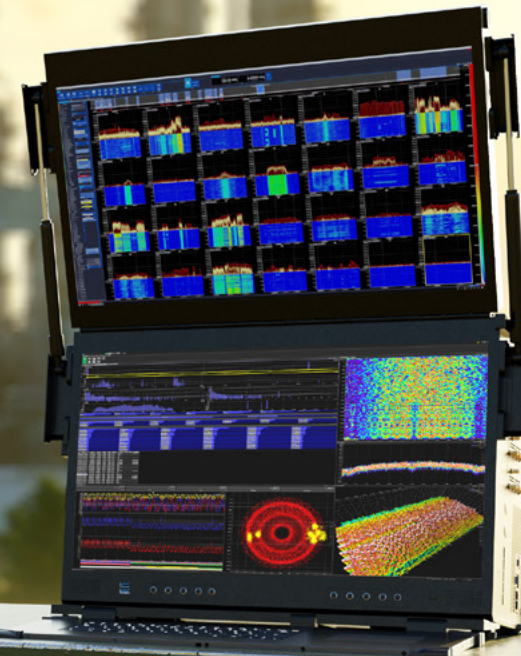

# AARONIA STATIONARY MESH

SCALABLE 24/7 SPECTRUM MANAGEMENT

## 24/7/365 Remote Spectrum Management.

The Aaronia **STATIONARY MESH** delivers cutting-edge 24/7 remote signal management, offering continuous surveillance and control over the radio spectrum. With mesh capability supporting an indefinite number of units, this system creates a scalable network capable of covering vast areas, even enabling nationwide spectrum overwatch.

Equipped with AoA (Angle of Arrival), PoA (Power of Arrival) or TDoA (Time Difference of Arrival) geolocation, the **STATIONARY MESH** provides precise 3D localization of signal sources, making it ideal for security, interference resolution, and regulatory enforcement.

The system's advanced data reduction technology ensures efficient processing and storage by eliminating redundant data, enabling faster analysis and streamlined workflows.

Designed to automatically search, classify, decode, and record signals of interest, the **STATIONARY MESH** ensures precise and efficient spectrum analysis without requiring constant manual intervention. Whether for regulatory compliance, security, or large-scale spectrum management, the Aaronia **STATIONARY MESH** offers unmatched scalability, precision, and reliability for managing complex signal environments.



> Power of Arrival locator



> 24/7/365 remote detection, classification and recording

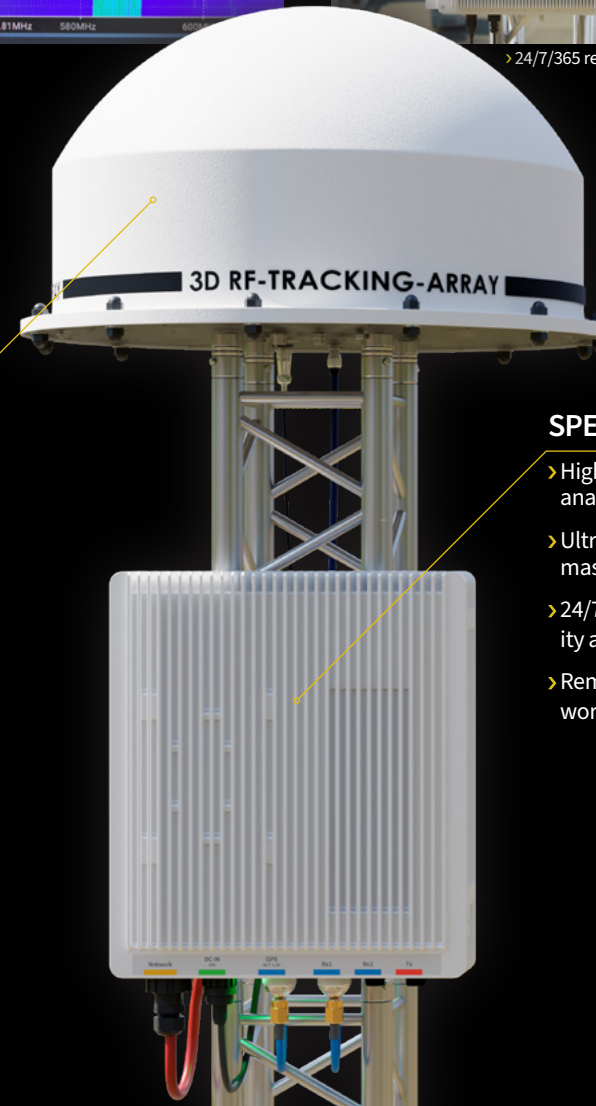

### IsoLOG® 3D 16-4080

- > Direction finding array with an exceptional accuracy of 1° to 3°
- > Broad frequency coverage of 400MHz up to 8GHz
- > Signal direction finding including elevation information
- > IP66 with ruggedized radome for continuous outdoor usage

### SPECTRAN® V6 RODB

- > High-end ruggedized real-time spectrum analyzer
- > Ultra fast sweeper with 3THz/s and/or massive real-time bandwidth of 490MHz
- > 24/7/365 outdoor usage with mesh-capability and remote control
- > Remote access via RJ45 or fiberwire network, LTE, or radio relay

# 24/7/365 Remote Spectrum Management



## SWEEP MESH

### Type

Omnidirectional

### Frequency Range

150MHz to 18GHz

### Signal Duration

>20 $\mu$ s

### PoA Accuracy

Typically < 50 meters

### TDoA Accuracy

Typically < 5 meters

### Sweep Speed

3THz/s

### RTBW

60MHz

## DF MESH

### Type

3D Direction Finding Array

### Frequency Range

400MHz to 8GHz

### Signal Duration

>2 $\mu$ s

### DF Accuracy

1 to 3°

### Sweep Speed

3THz/s

### RTBW

490MHz

# AARONIA INTEGRATED SYSTEMS

FULL-SPECTRUM CONTROL ON THE MOVE

## Spectrum Control Anywhere, Anytime.

The Aaronia **INTEGRATED SYSTEMS** offers unparalleled spectrum management capabilities, seamlessly integrated into SUVs, vans, offroad pickup trucks, or stationary operator compartments. Designed for both overt and covert operations, these versatile solutions deliver precision and performance tailored to demanding environments.

Fully self-sufficient, each system is equipped with a built-in diesel generator or fuel cell, ensuring uninterrupted power supply for extended missions. The air-conditioned operator compartment provides a comfortable, high-tech workspace, featuring four 4K screens and high-end server technology for real-time monitoring, analysis, and data processing.

With massive high-speed recording space, the **INTEGRATED SYSTEMS** allows for continuous capture of critical spectrum data, supporting detailed post-event analysis. For covert operations, limited-efficiency solutions ensure discreet deployment without compromising effectiveness.

Achieving TRL-9 (Technology Readiness Level) and MRL-10 (Manufacturing Readiness Level), Aaronia's **INTEGRATED SYSTEMS** are fully operational and ready for deployment in the field. Whether for spectrum monitoring, interference detection, or signal analysis, these mobile units provide robust, adaptable, and reliable performance in even the most challenging conditions.



› Customized hardware for covert operations or the integration in existing vehicles



› Rugged electronic warfare platform with superior off-road capabilities

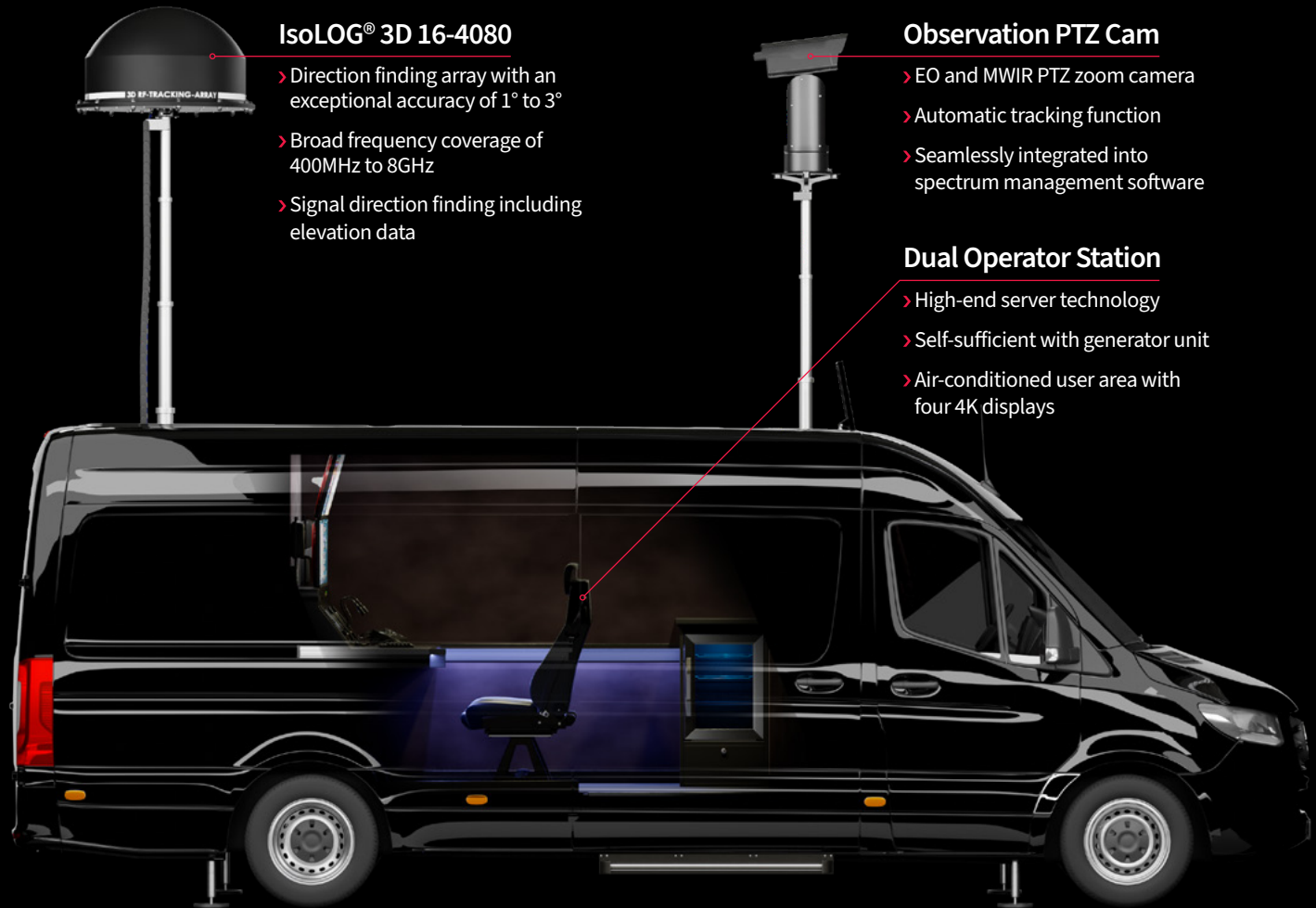

### IsoLOG® 3D 16-4080

- › Direction finding array with an exceptional accuracy of 1° to 3°
- › Broad frequency coverage of 400MHz to 8GHz
- › Signal direction finding including elevation data

### Observation PTZ Cam

- › EO and MWIR PTZ zoom camera
- › Automatic tracking function
- › Seamlessly integrated into spectrum management software

### Dual Operator Station

- › High-end server technology
- › Self-sufficient with generator unit
- › Air-conditioned user area with four 4K displays

# Spectrum Control Anywhere, Anytime

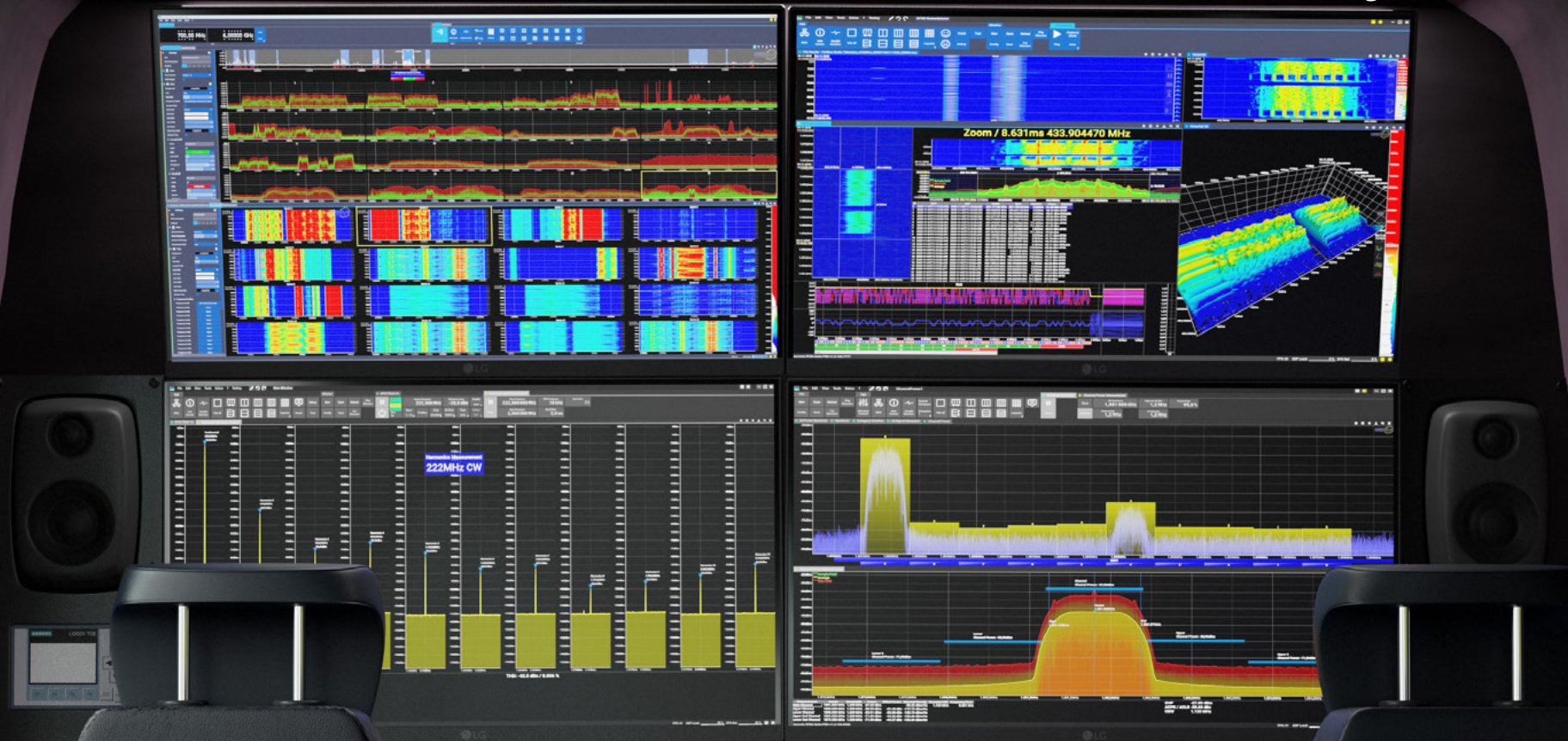

## Type

Direction Finding Array

## Frequency Range

400MHz to 8GHz

## Signal Duration

>3 $\mu$ s

## DF Accuracy

1 to 3°

## Sweep Speed

3Hz/s

## RTBW

1.470MHz

# AARONIA RTSA-SUITE PRO

MISSION-CRITICAL PRECISION

RTSA-Suite PRO is the world's fastest real-time spectrum analysis software, expertly designed for the latest SPECTRAN® instruments. Delivering unmatched speed and precision, it sets a new standard for modern spectrum analysis, offering exceptional capabilities for professionals across industries.

The software seamlessly integrates with various hardware components, supporting comprehensive evaluation across diverse applications. Its intuitive block-based configuration system simplifies setup, delivering optimal settings for almost any scenario.

RTSA-Suite PRO enables real-time spectrum analysis with broad frequency coverage, customizable FFT sizes (up to 1B), and seamless IQ data recording. Advanced visualization tools, like 3D and waterfall displays, and specialized blocks for tasks such as IQ WiFi drone detection or drive test with heat map and record function, ensure precise results. Remote operation via HTTP simplifies integration with custom workflows.

With drag-and-drop mission management, multitasking, and compatibility with Windows and Linux, RTSA-Suite PRO provides a user-friendly experience. A powerful API supports custom

workflows, third-party tools, and automation, while regular updates keep your analysis capabilities cutting-edge:

- › Gapless real-time 3D views
- › Unlimited recording time
- › Simultaneous support for multiple devices
- › Real-time demodulation and 3D trigger

Supporting 3.0 connections, up to 20GHz real-time bandwidth, and full MATLAB compatibility, RTSA-Suite PRO is the ultimate solution for virtually limitless measurement scenarios.

Experience the perfect blend of speed, flexibility, and cutting-edge innovation. Whether for high-speed signal detection, complex analysis, or advanced visualization, RTSA-Suite PRO delivers a powerful, flexible solution designed to meet the demands of modern spectrum analysis.

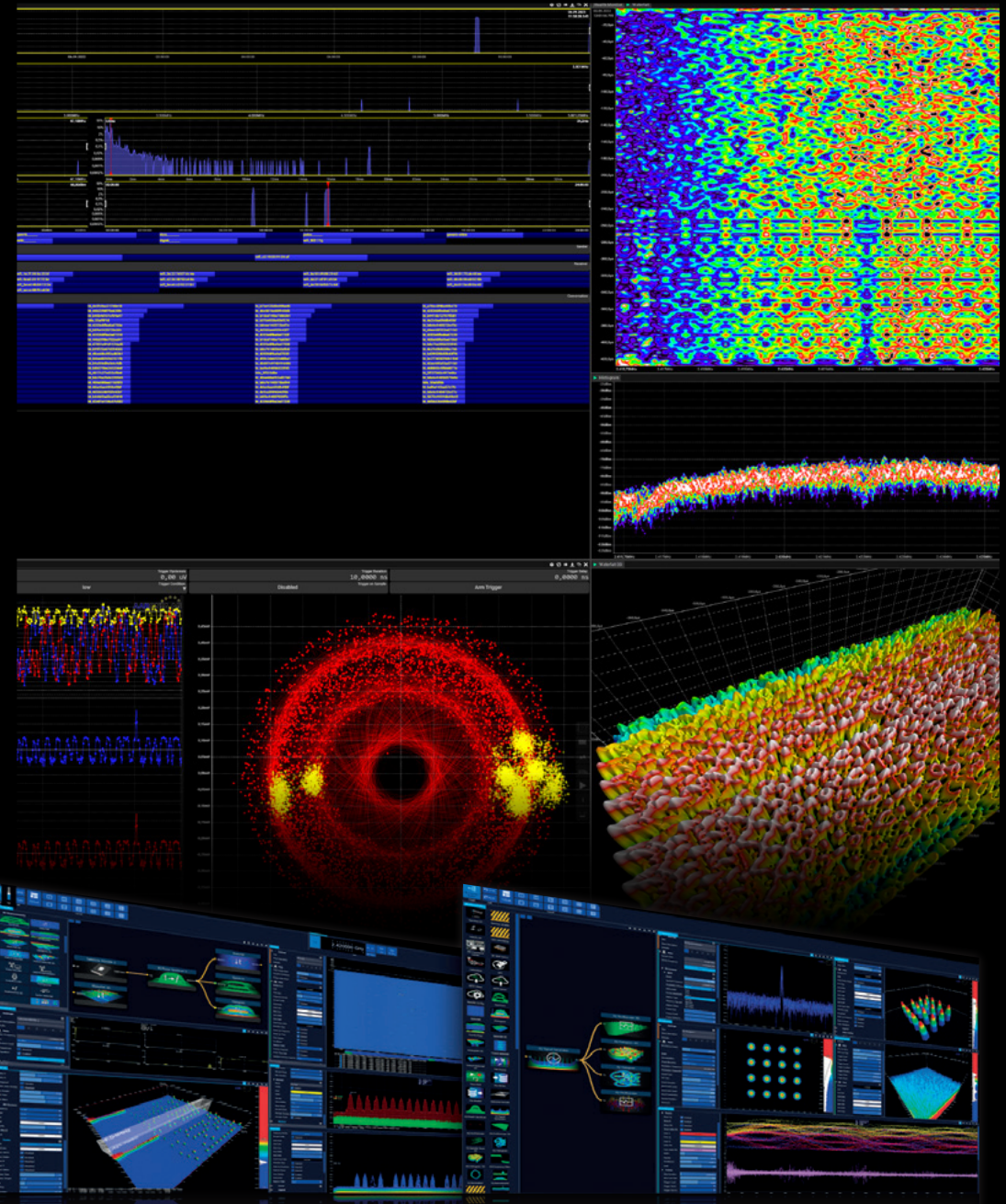

# AARONIA WORLDWIDE

ALWAYS AT THE FOREFRONT OF TECHNOLOGY



EUROPE | Niederösterreichische Landesregierung, Austria | Ministry of Defense, Austria | Border Control, Latvia | Ministry of Defence, UK | MOD DSTL, UK | Federal Politie, Belgium | Bulgarian Air Charter, Bulgaria | Estonian Defence Forces | Finnish Defence Forces | Cargolux Airlines, Luxembourg | Swedish Defense Research Agency | Portuguese Air Force | FMW Swedish Defense Material Administration | Swedish Armed Forces | Heathrow Airport, UK | Cobra, Austria | Police, Malta | Turkish National Police | Police, Zypern | GERMANY | BUND, Germany | Bundesamt für Polizei | Bundesamt für Sicherheit in Informationstechnik | Bundesamt für Verfassungsschutz | Bundesamt der Verteidigung | Bundeskriminalamt | Bundesnachrichtendienst | Bundesnetzagentur | DFS – Dt. Flugsicherung | WORLDWIDE | Ministry of Defence, Indonesia | Air Forces, Thailand | Ministry of Defence, Australia | Gendarmerie Royale, Morocco | Ministry of Defence, Kenya | Ministry of Defence, Uganda | Ministry of Defence, Ruanda | Ministry of Defence, Ukraine



Aaronia is an internationally-renowned company founded in 2003 and headquartered in Strickscheid, Germany. We specialize in measuring, tracking and monitoring technology that is second to none and is a staple in many fields.

The company is headquartered in the picturesque Eifel region of rural Germany, where its state-of-the-art high-tech campus serves as the hub for research,

development, and production. This unique location combines the tranquility of the countryside with cutting-edge facilities, fostering innovation and technological excellence.

Renowned for precision and reliability, Aaronia combines German engineering excellence with a commitment to delivering high-performance solutions trusted worldwide.

Aaronia delivered its first Spectrum Analyzer in 2004, marking the start of a legacy in spectrum analysis innovation. In 2008, the V4 series broke records with a world-leading handheld sensitivity of DANL -170 dBm (Hz).

Since 2020, the 6th generation of SPECTRAN® analyzers has been on the market, offering real-time measurement capabilities that have redefined industry standards.

With the latest advancements, Aaronia introduces 490 MHz real-time bandwidth and a staggering 3 THz/s sweep speed, setting new benchmarks for speed and precision.

These features make the new generation of SPECTRAN® analyzers ideal for even the most demanding applications, solidifying Aaronia's position as a leader in cutting-edge spectrum analysis technology.



Aaronia AG has consistently pushed the boundaries of RF and EMF measurement technology, establishing itself as a global leader in high-performance solutions. The company's flagship SPECTRAN® V6 series has set new benchmarks in the USB compact class.

By cascading multiple SPECTRAN® devices, Aaronia achieves real-time bandwidths in the gigahertz range, enabling unparalleled performance in spectrum analysis. These systems are deployed globally,

from individual installations to complex integrated networks, showcasing their versatility and robust functionality.

This innovative approach is also the foundation for AARTOS™, the world's most powerful UAV detection system, with over 650 installations worldwide. AARTOS™ combines precision and scalability, making it a trusted choice for detecting and mitigating drone threats in security and defense applications.

Aaronia's core mission encompasses the development, trade, and distribution of advanced measurement instruments and technologies. Its expertise spans low- and high-frequency measurement technology, robotics, and the shielding of electromagnetic fields.

The company also conducts basic research in communications and measurement technology, developing proprietary circuits and measurement meth-

ods that deliver extreme sensitivity and precision in high-frequency applications.

With a commitment to innovation and excellence, Aaronia continues to shape the future of RF measurement technology, providing groundbreaking solutions for diverse industries and applications.

**Find out more at [www.aaronia.com](http://www.aaronia.com)**

Digital Download "Aaronia Main Catalog"



Digital Download "Aaronia Spectrum Awareness & 3D Geolocation"

